

DO it

We thought of you!



ORIGINE
FRANCE[®]
GARANTIE

BVCert. 6164725

ERARD[®]

do it range

Complete range for extra slim screens



THE SCREEN IS AS CLOSE THE WALL AS POSSIBLE

16 mm with a fixed, 30 mm with a tilting;
42 mm with a tilting/swivelling wall mount.



WALL PLATE HORIZONTALITY ADJUSTMENT

Feasible after drilling thanks to a patented installation system with 4 off-centre washers.

Easy assembly: 1 person is enough.



INTEGRATED SPIRIT LEVEL

Makes it easy to check horizontality when installing.



SECURITY SYSTEM PREVENTING FALLS

Automatic screen locking.

Unlocking cable with adjustable length.

“CLIC” indicating locking and unlocking.

FiXiT

Fixed ultra slim wall mount for LED screens for a beautiful “as a picture on the wall” effect

TiLTiT

Tilting ultra slim wall mount to:

- Set the TV higher up on the wall
- Avoid glares on the screen
- Access to the plugs on rear of the screen and easier plugging of miscellaneous mobile devices

TWISTiT

Tilting and swivelling ultra slim mount to :

- Swivel the TV 90° left and right
- Position the TV in a corner
- Position the screen perpendicular to the wall
- Benefit from the same advantages than with TiLTiT



BVCert. 6164725

**10 YEAR
GUARANTEE**

do it range

Complete range for extra slim screens

M 19"-32"
48-81cm

L 30"-55"
76-140cm

XL 40"-75"
102-190cm

19" 30" 32" 42" 55" 75"

TWISTIT 400
TILTING
AND SWIVELLING



44440

TILTIT 400
TILTING



44240

FIXIT
FIXED



44020



44040



44060

FiXiT 200

- For SLIM / LED screens and compatible with 19" – 32" LCD – plasma screens
- Tested up to 150 kg

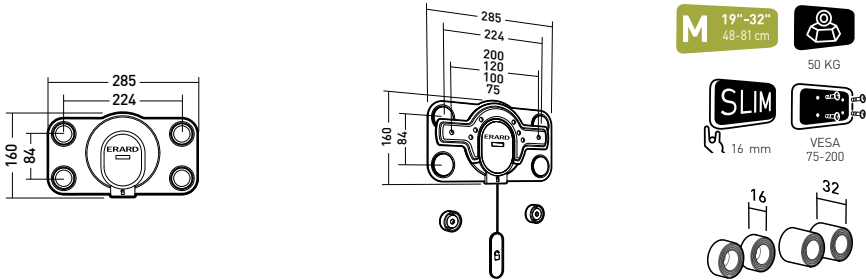

FiXiT 400

- For SLIM / LED screens and compatible with 30" – 50" LCD – plasma screens
- Tested up to 200 kg

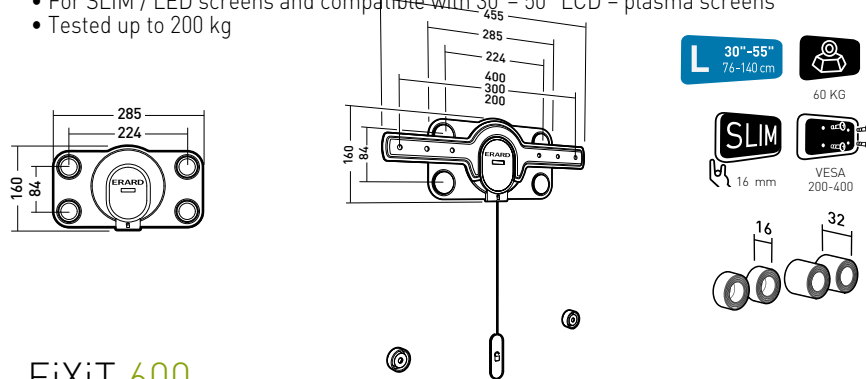

FiXiT 600

- For SLIM / LED screens and compatible with 42" – 65" LCD – plasma screens
- Tested up to 280 kg

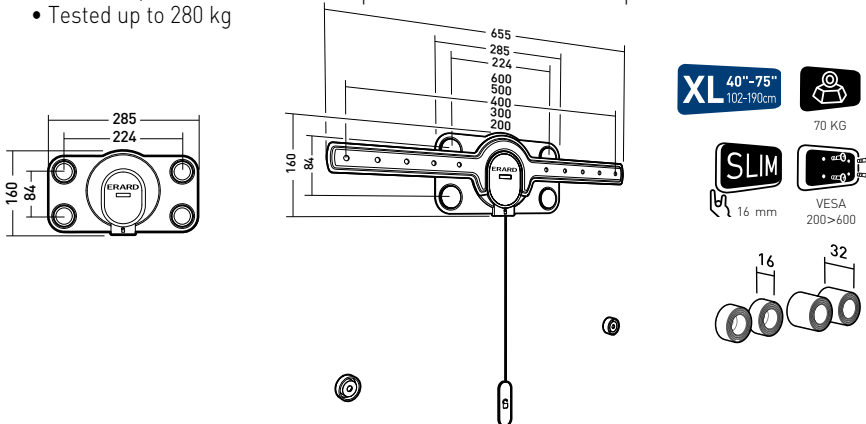

10 YEAR
GUARANTEE

TiLTiT

Technical details

TiLTiT 400

- For SLIM/LED screens and compatible with 30" - 52" LCD - plasma screens
- Tested up to 120 kg

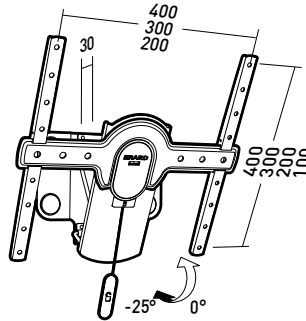
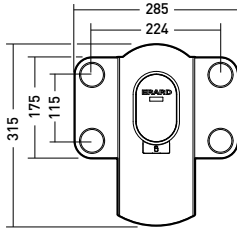

L 30"-55"
76-140 cm



TWiSTiT 400

- For SLIM/LED screens and compatible with 30" - 52" LCD - plasma screens
- Tested up to 120 kg

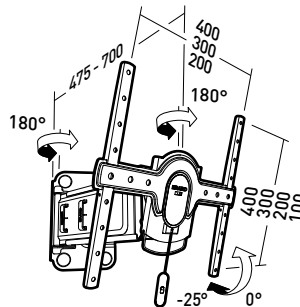
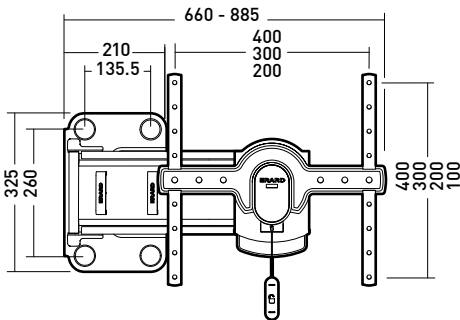

L 30"-55"
76-140 cm



Adjustable
arm
with integrated
ruler

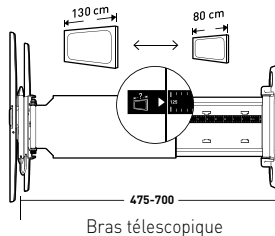

Merchandising FIXiT, TiLTiT, TWiSTiT

The *do it* range holds a special place in our merchandising offer. Both innovative and attractive, it deserves tools which are up to its performances.



POS FIXiT
Ref. 002699 Without cables and connectors
Ref. 002698 With cables and connectors



Packaging



POS
DO iT range
Ref. 002719



Discover FiXiT, TiLTiT and
TWiSTiT demo videos

FiXiT**TiLTiT****TWiSTiT**

Ref.	044020	FiXiT 200	EAN	318528 044020 7
Ref.	044040	FiXiT 400	EAN	318528 044040 5
Ref.	044060	FiXiT 600	EAN	318528 044060 3
Ref.	044240	TiLTiT 400	EAN	318528 044240 9
Ref.	044440	TWiSTiT 400	EAN	318528 044440 3



Mounts and furniture
for flat TV screens Catalogue



Mounting systems for antennas
and satellite dishes Catalogue



Connection systems
catalogues



ERARD Pro catalogue

ERARD®

ESSENTIAL **ACCESSORIES**
FOR AUDIO VIDEO COMPONENTS

WWW.ERARD.COM / Mail : INFOS@ERARD.FR / Tél : +33(0)4 72 46 16 26 / Fax : +33(0)4 72 46 16 22

VAT N°: FR 19 613 680 073

Z.I. de Chavanoz / 4 route de la Plaine / 38236 PONT DE CHERUY Cedex / FRANCE