

INSTALLATION INSTRUCTIONS

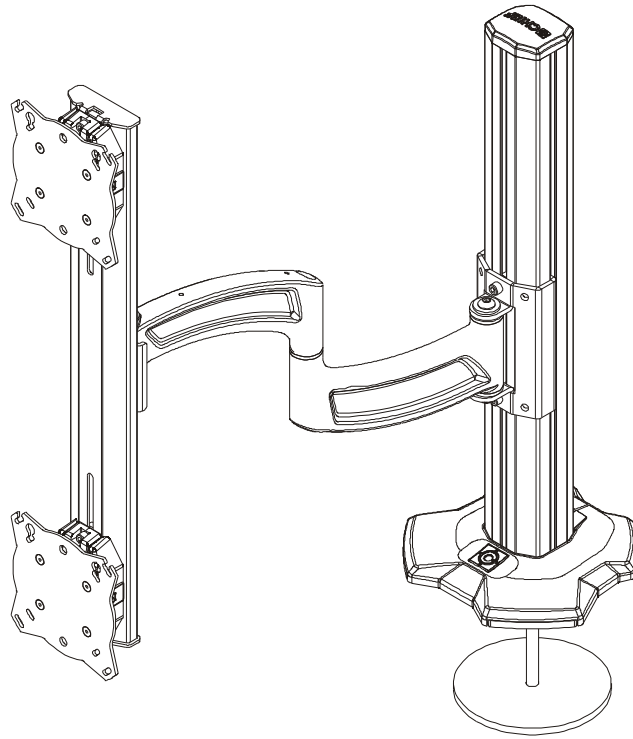

Kontour™ Articulating Array Arm

DISCLAIMER

Milestone AV Technologies and its affiliated corporations and subsidiaries (collectively "Milestone"), intend to make this manual accurate and complete. However, Milestone makes no claim that the information contained herein covers all details, conditions or variations, nor does it provide for every possible contingency in connection with the installation or use of this product. The information contained in this document is subject to change without notice or obligation of any kind. Milestone makes no representation of warranty, expressed or implied, regarding the information contained herein. Milestone assumes no responsibility for accuracy, completeness or sufficiency of the information contained in this document.

Chief® is a registered trademark of Milestone AV Technologies. All rights reserved.



WARNING: Never operate this mounting system if it is damaged. Return the mounting system to a service center for examination and repair.



WARNING: Do not use this product outdoors.

--SAVE THESE INSTRUCTIONS--



IMPORTANT SAFETY INSTRUCTIONS



WARNING: A WARNING alerts you to the possibility of serious injury or death if you do not follow the instructions.



CAUTION: A CAUTION alerts you to the possibility of damage or destruction of equipment if you do not follow the corresponding instructions.



WARNING: Failure to read, thoroughly understand, and follow all instructions can result in serious personal injury, damage to equipment, or voiding of factory warranty! It is the installer's responsibility to make sure all components are properly assembled and installed using the instructions provided.



WARNING: Failure to provide adequate structural strength for this component can result in serious personal injury or damage to equipment! It is the installer's responsibility to make sure the structure to which this component is attached can support five times the combined weight of all equipment. Reinforce the structure as required before installing the component.



WARNING: Exceeding the weight capacity can result in serious personal injury or damage to equipment! It is the installer's responsibility to make sure the combined weight of all components located on the K4G120 mount up to (and including) the display does not exceed 15 lbs (6.8 kg) per display.







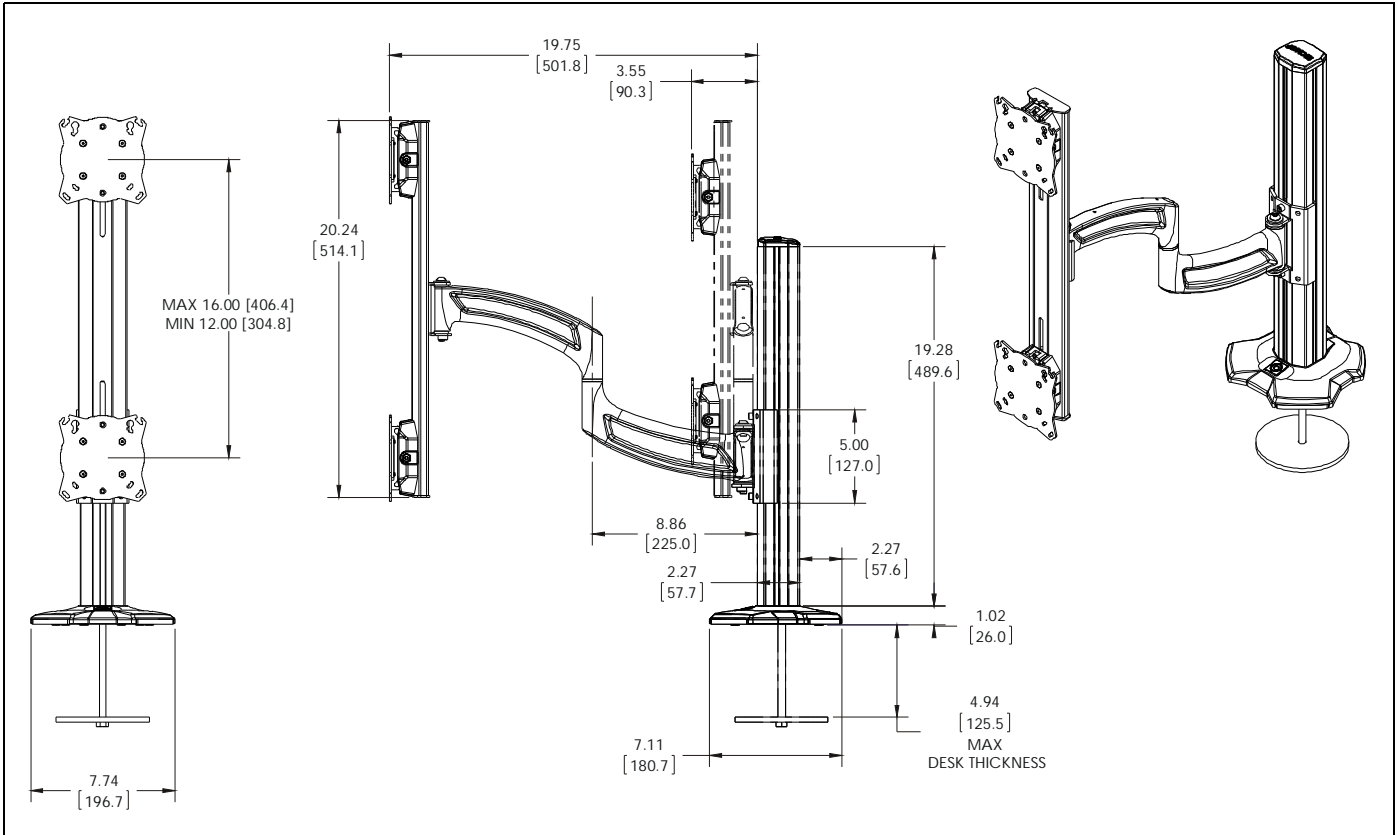



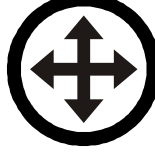

WARNING: Use this mounting system only for its intended use as described in these instructions. Do not use attachments not recommended by the manufacturer.

DIMENSIONS



LEGEND

	Tighten Fastener Apretar elemento de fijación Befestigungsteil festziehen Apertar fixador Serrare il fissaggio Bevestiging vastdraaien Serrez les fixations		Pencil Mark Marcar con lápiz Stiftmarkierung Marcar com lápis Segno a matita Potloodmerkteken Marquage au crayon
	Loosen Fastener Aflojar elemento de fijación Befestigungsteil lösen Desapertar fixador Allentare il fissaggio Bevestiging losdraaien Desserrez les fixations		Drill Hole Perforar Bohrloch Fazer furo Praticare un foro Gat boren Percez un trou
	Phillips Screwdriver Destornillador Phillips Kreuzschlitzschraubendreher Chave de fendas Phillips Cacciavite a stella Kruiskopschroevendraaier Tournevis à pointe cruciforme		Adjust Ajustar Einstellen Ajustar Regolare Afstellen Ajuster
	Open-Ended Wrench Llave de boca Gabelschlüssel Chave de bocas Chiave a punte aperte Steeksleutel Clé à fourche		Remove Quitar Entfernen Remover Rimuovere Verwijderen Retirez
	By Hand A mano Von Hand Com a mão A mano Met de hand À la main		Optional Opcional Optional Opcional Opzionale Optie En option
	Hex-Head Wrench Llave de cabeza hexagonal Sechskantschlüssel Chave de cabeça sextavada Chiave esagonale Zeskantsleutel Clé à tête hexagonale		Security Wrench Llave de seguridad Sicherheitsschlüssel Chave de segurança Chiave di sicurezza Veiligheidsleutel Clé de sécurité

TOOLS REQUIRED FOR INSTALLATION

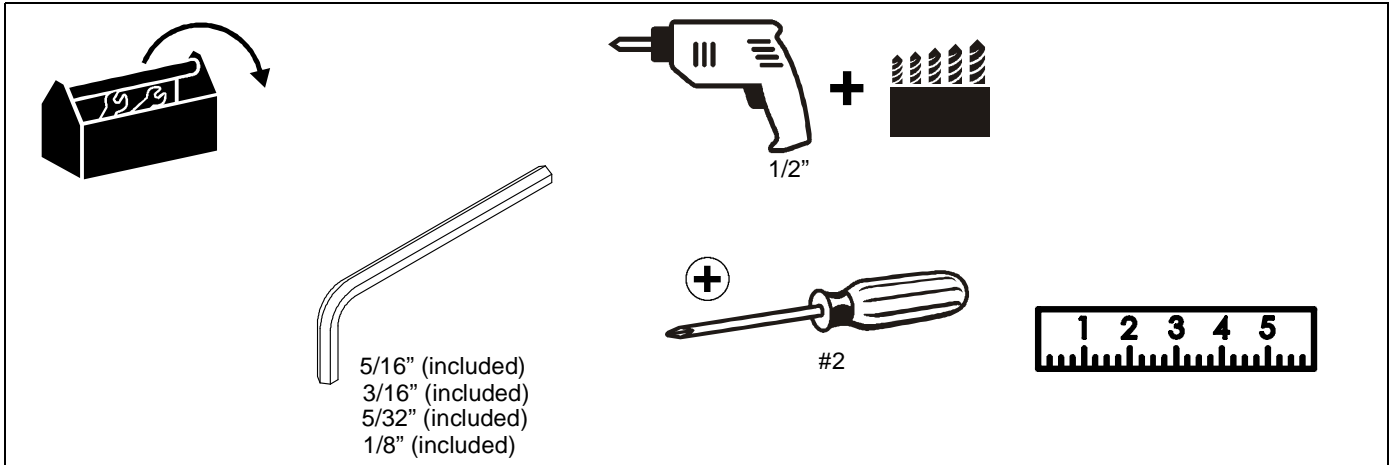

PARTS

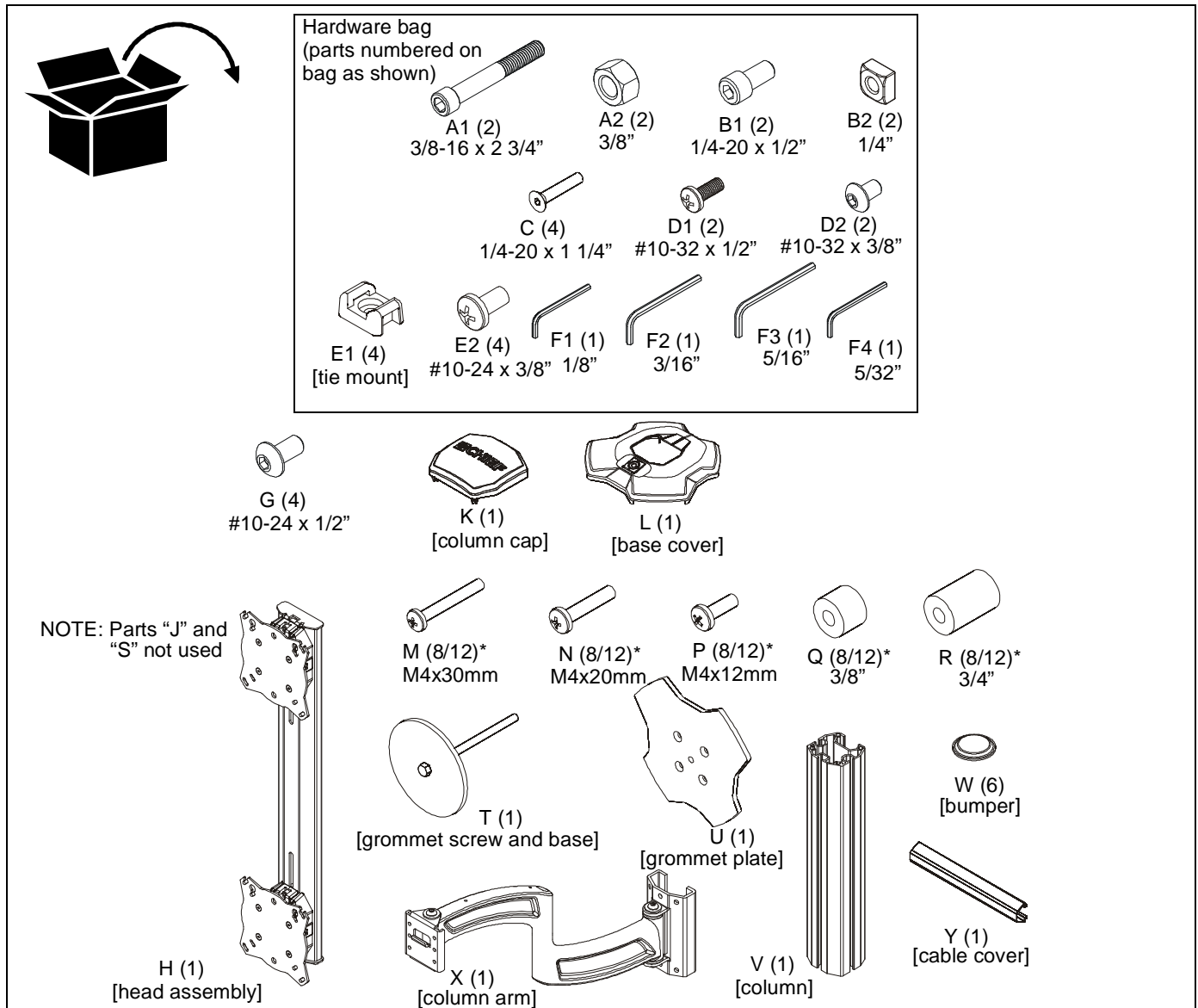

Assembly And Installation

1. Use four 1/4-20 x 1 1/4" flat head cap screws (C) to secure grommet plate (U) to column (V). Make sure longer legs of grommet plate are aligned with the front of column. (See Figure 1)

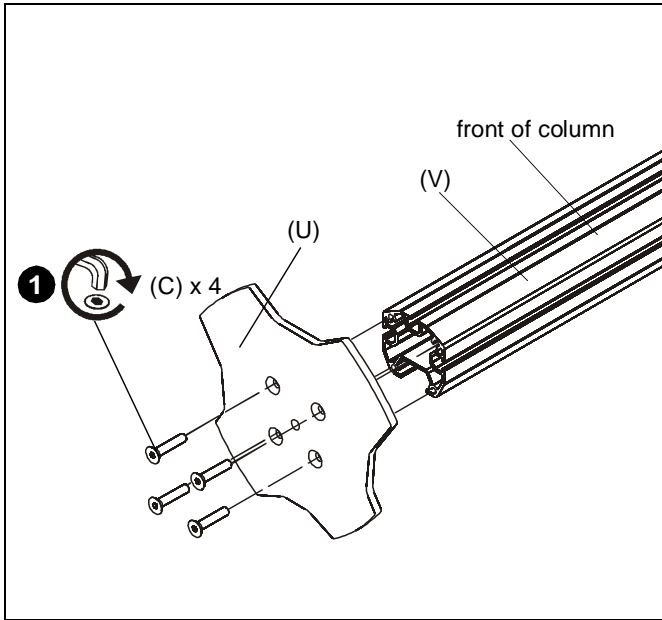

Figure 1

2. Apply bumpers (W) to underside of grommet plate (U). (See Figure 2)

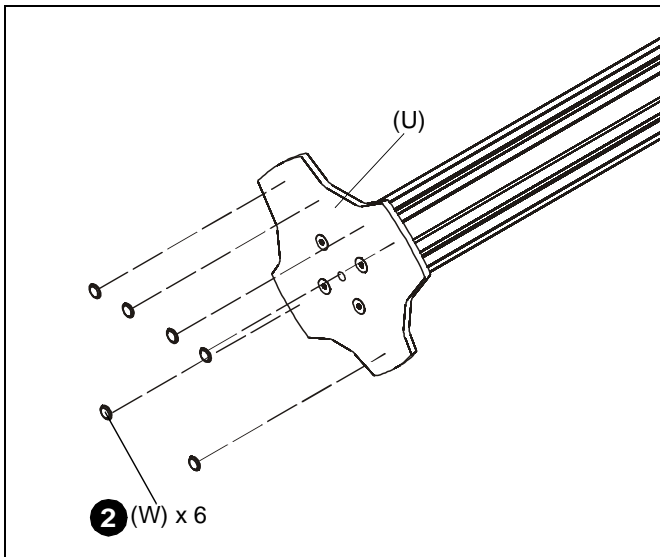

Figure 2

3. Locate a flat surface (thickness minimum of 1" to maximum of 5") on which to mount the array assembly.
4. If a hole doesn't already exist, drill a hole in desk with a diameter between 1/2" and 3 1/2" at desired mounting location. (See Figure 3)
5. Position mount on desk so that center hole of grommet plate (U) is centered over grommet hole. (See Figure 3)

6. Insert grommet screw (T) through grommet hole and thread into center hole of grommet plate (U). (See Figure 3)
7. Tighten grommet screw (T) until grommet base is tightened against underside of desk and mount is securely mounted to desk. (See Figure 3)

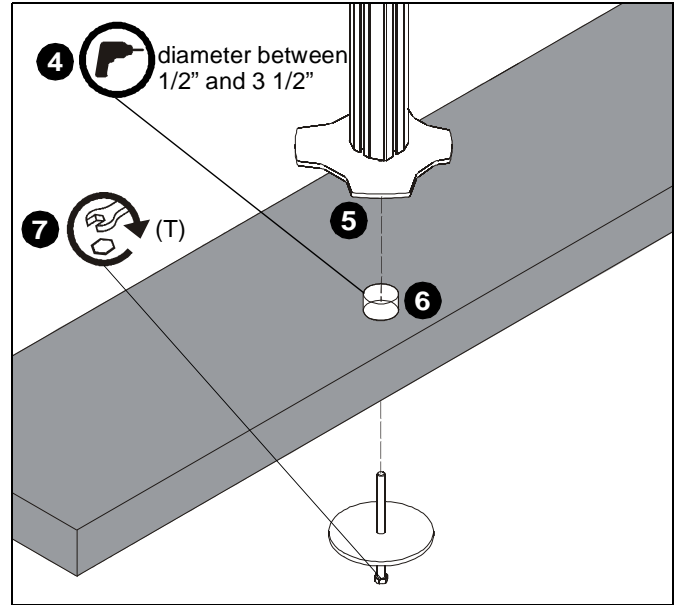

Figure 3

8. Carefully manipulate base cover (L) to create an opening large enough to wrap cover around array column. (See Figure 4)
9. Wrap base cover (L) around column and slide it down until base cover fits securely onto grommet plate (U). (See Figure 4)

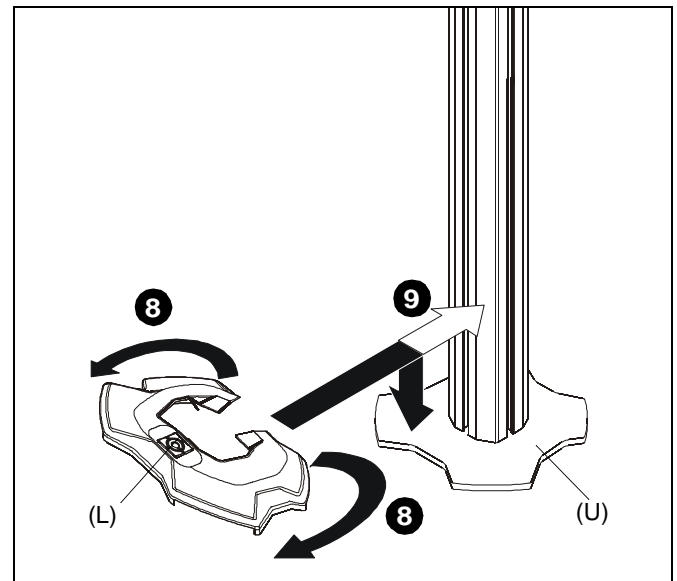

Figure 4

- 10. Loosely install two 1/4-20 x 1/2" socket head carriage screws (B1) through mounting holes on column arm (Z) bracket and into 1/4" square nuts (B2). (See Figure 5)
- 11. Slide column arm (Z) bracket into column (V) until desired mounting height is reached. (See Figure 5)

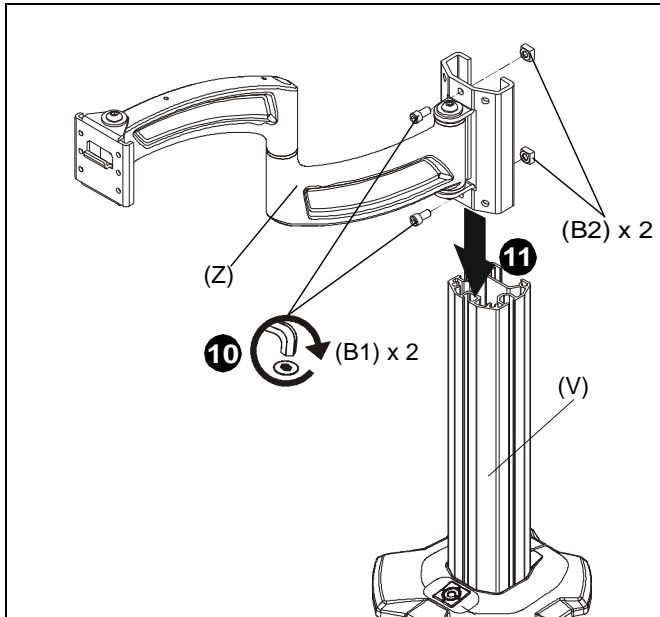

Figure 5

- 12. Tighten two 1/4-20 x 1/2" socket head carriage screws (B1) to secure column arm (X) at desired height. (See Figure 6)
- 13. Install column cap (K) to column (V). (See Figure 6)

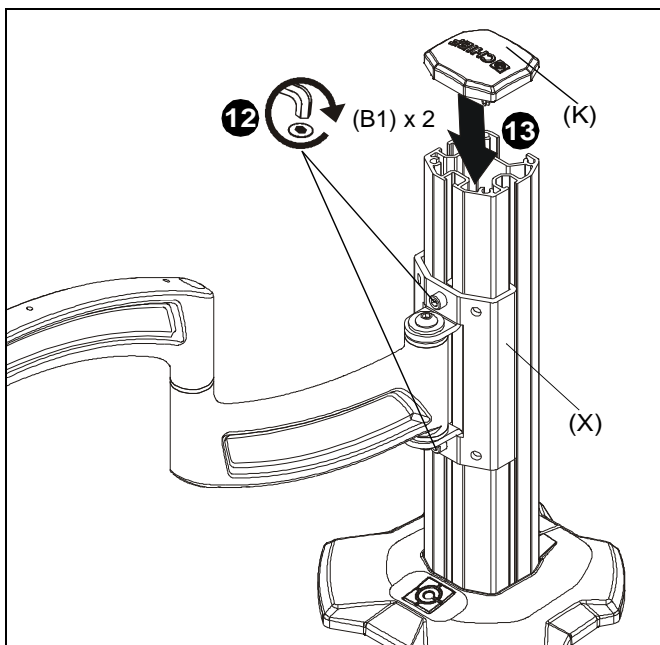

Figure 6

- 14. Use four #10-24 x 1/2" button head cap screws (G) to secure head assembly (H) to arm assembly (X). (See Figure 7)

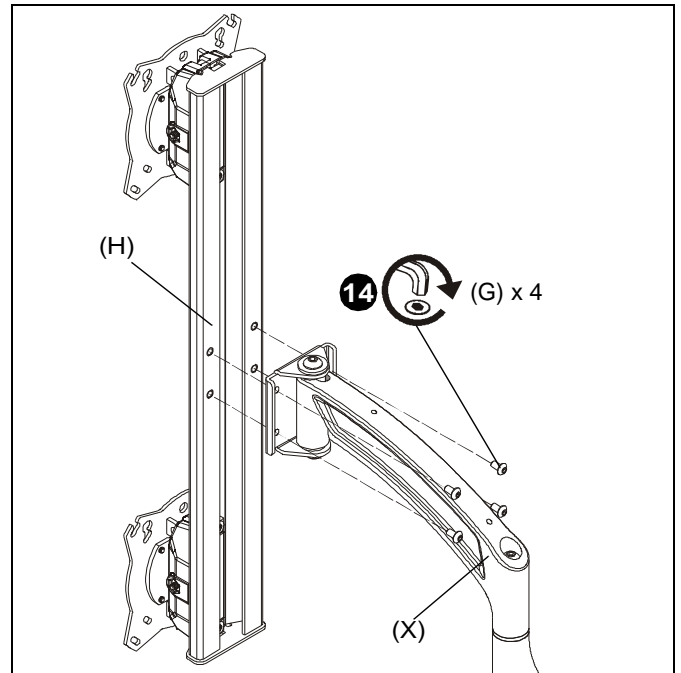

Figure 7

Display Installation

Faceplate Positioning

1. Loosen height adjustment screws for each faceplate to adjust height. (See Figure 8)
2. Adjust faceplates to desired height. (See Figure 8)

IMPORTANT ! : In order to install displays with no gap in between displays, distance between faceplates must equal the height of each display. (See Figure 9)

NOTE: Faceplates may be positioned a minimum of 12" apart and a maximum of 16" apart. (See Figure 9)

3. Tighten height adjustment screws to lock display's position. (See Figure 8)

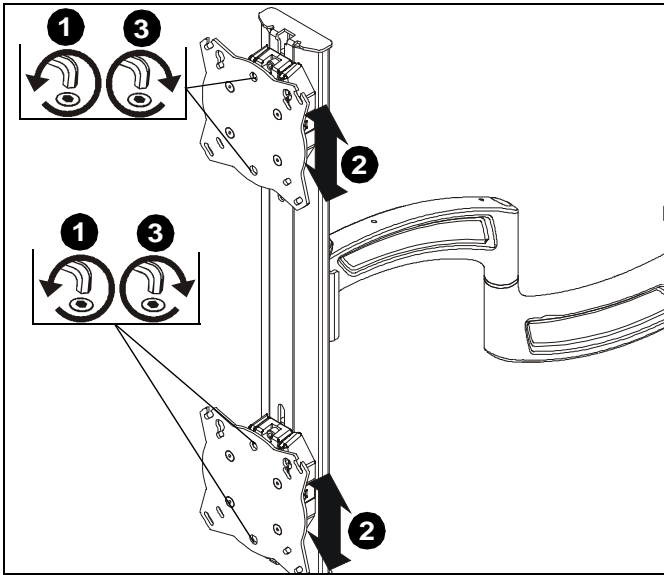

Figure 8

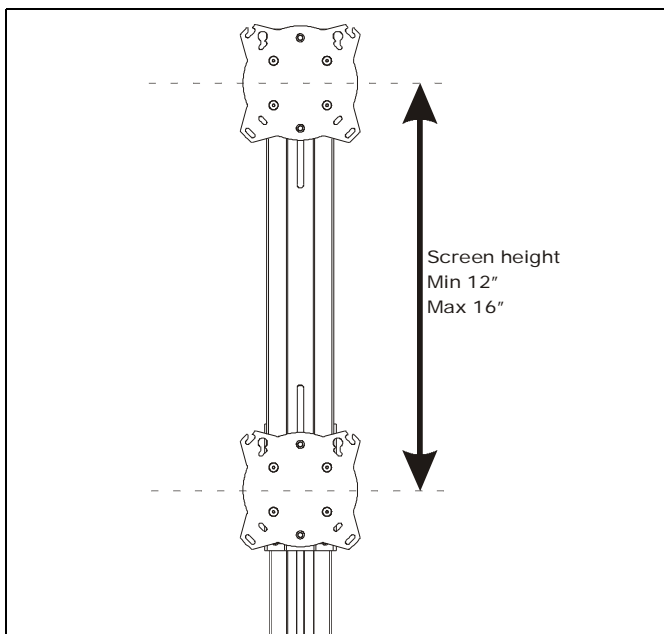

Figure 9



WARNING: Exceeding the weight capacity can result in serious personal injury or damage to equipment! It is the installer's responsibility to make sure the combined weight of all components located on the K4G120 mount up to (and including) the display does not exceed 15 lbs (6.8 kg) per display.



CAUTION: Using screws of improper size may damage your display! Proper screws will easily thread into display mounting holes.

NOTE: Supplied screws (M, N and P) may not fit properly for all displays. See display's operating instructions for details.

Flush Mounting Holes

IMPORTANT ! : Lower display must be installed before installing upper display!

1. Using Phillips screwdriver, carefully install two M4 x 12mm Phillips pan machine screws (P) into the *upper* mounting holes on the display. Thread screws completely into display, then back out 3 complete turns. (See Figure 10)

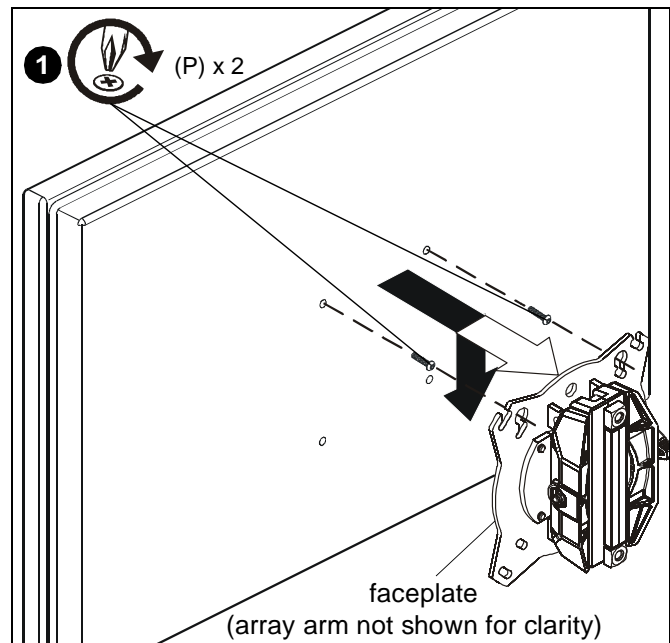

Figure 10

2. Pick up and align display so that screws (P) (installed on the back of the display in the previous step) fit into the mounting holes on the faceplate. Lower the display firmly into place. (See Figure 10)
3. Using Phillips screwdriver, install two M4x12 mm Phillips pan machine screws (P) through the *lower* mounting holes on faceplate into the display. (See Figure 11)

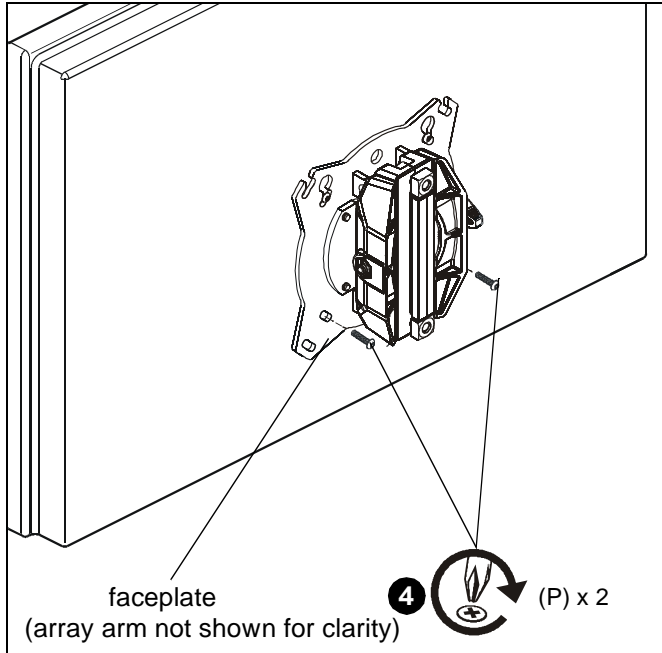

Figure 11

4. Tighten all four screws (P). Do not over-tighten!

NOTE: If roll adjustment is desired, do not tighten screws.

5. Repeat Steps 1-4 for upper display.

6. Proceed to Adjustments Section.

Recessed Mounting Holes

IMPORTANT ! : Lower display must be installed before installing upper display!

NOTE: If faceplate does not fit into recessed area of display, proceed with the steps in this section.

1. Determine depth of recessed mounting holes relative to back surface of display (against which faceplate will contact).

2. Select proper length spacer and screw from table below:

NOTE: All spacers used should be the same length. If the recess depths result in multiple spacer lengths, then select the longer spacer.

IF recess DEPTH is:	THEN use spacer:	AND screw:
3/8" or less	Q (3/8" long)	N (M4 x 20mm)
More than 3/8" up to and including 3/4"	R (3/4" long)	M (M4 x 30mm)



CAUTION: Using screws of improper size may damage your display! Proper screws will easily and completely thread into display mounting holes.

3. Using Phillips screwdriver, carefully install two selected screws (N or M) through selected spacers (Q or R) into the upper mounting holes on the display. Thread screws completely into display, then back out 3 complete turns. (See Figure 12)

4. Pick up and align display so that screws (N or M) (installed on the back of the display in the previous step) fit into the mounting holes on the faceplate. Lower the display firmly into place. (See Figure 12)

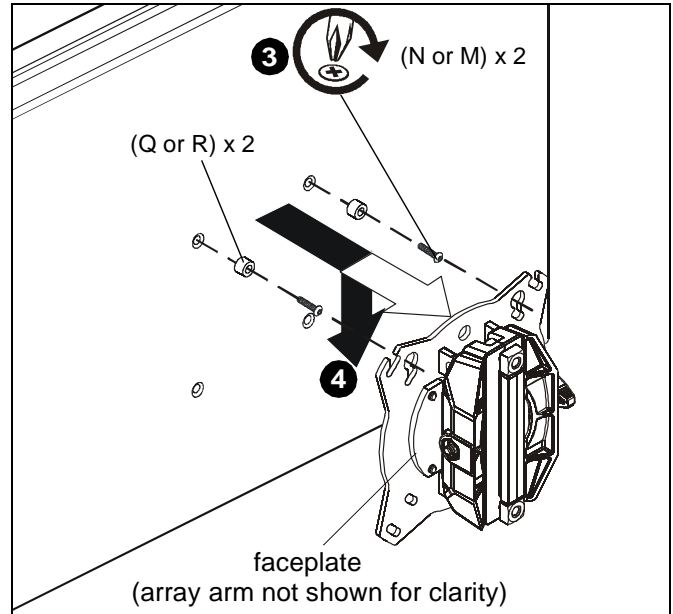

Figure 12

5. Slide two remaining selected spacers (Q or R) in between faceplate and display, positioning them over the lower two mounting holes. (See Figure 13)

6. Install two remaining selected screws (N or M) through lower two mounting holes on faceplate, selected spacers (Q or R) into the lower mounting holes on the display. (See Figure 13)

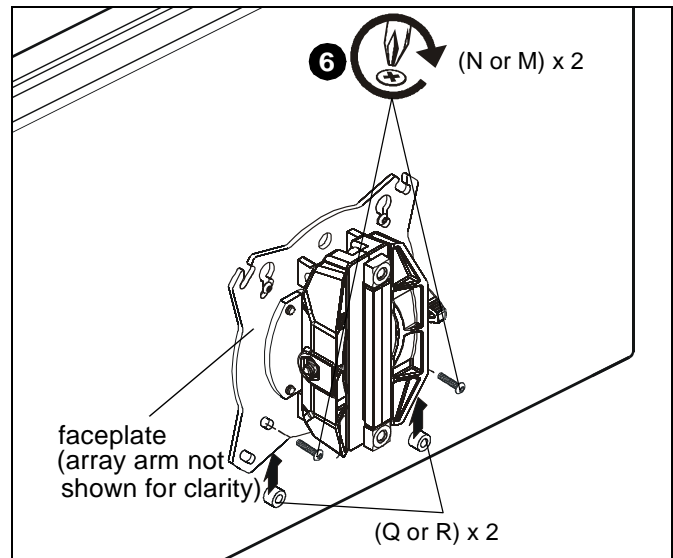

Figure 13

7. Tighten all four screws. Do not over-tighten!

8. Repeat Steps 3-7 for upper display.

Adjustments

Pivot Adjustment

1. Extend or collapse column arm (X) as desired. (See Figure 14)
2. (Optional) Loosen or tighten column arm pivot tension screws as desired to increase or decrease pivot tension. (See Figure 14)

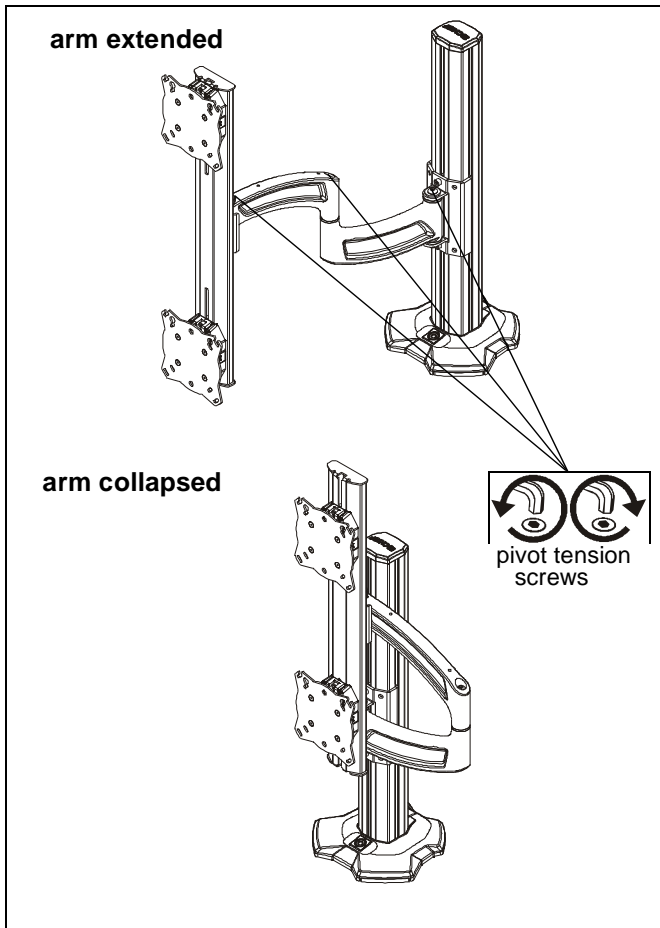

Figure 14

Height Adjustment (On Column)

1. Loosen 1/4-20 x 1/2" socket head carriage screws (B1) holding column arm (X) to column (V). (See Figure 15)
2. Adjust column arm to desired height. (See Figure 15)
3. Tighten 1/4-20 x 1/2" socket head carriage screws (B1) to lock column arm's position. (See Figure 15)

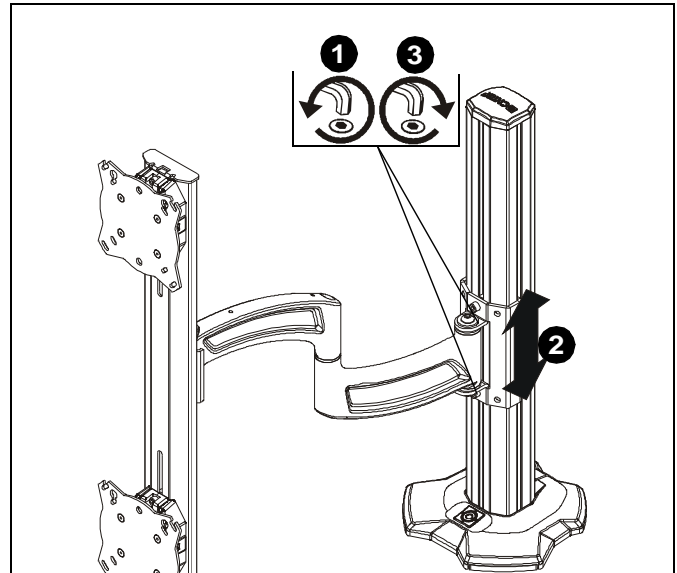

Figure 15

Height Adjustment (Faceplates)

NOTE: Remove display from faceplate in order to expose height adjustment screws.

1. Loosen height adjustment screws for specific display that will be adjusted. (See Figure 16)
2. Adjust display to desired height. (See Figure 16)
3. Tighten height adjustment screws to lock display's position. (See Figure 16)

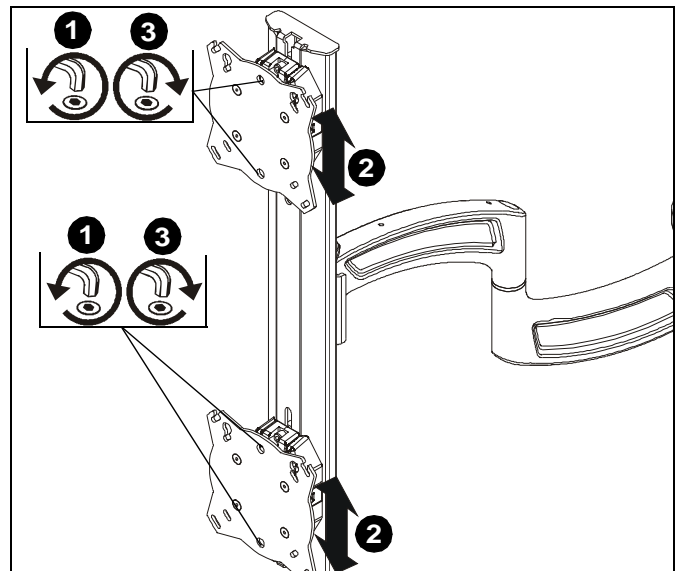

Figure 16

Pitch

1. Loosen knob on side of center faceplate assembly. (See Figure 17)
2. Adjust pitch as desired. (See Figure 17)
3. Tighten knob to secure desired pitch position. (See Figure 17)

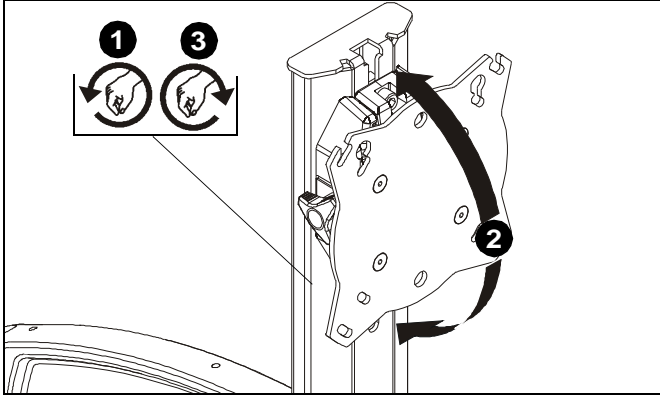

Figure 17

Roll

1. Loosen screws holding display to faceplate slightly.
2. Adjust roll position as the mounting holes on faceplate allow.
3. Tighten screws to lock roll position.

Cable Management - Clips

1. Use two #10-24 x 3/8" button head cap screws (E2) to attach two tie mounts (E1) to upper mounting arm. (See Figure 18)
2. Use two #10-24 x 3/8" button head cap screws (E2) to attach two tie mounts (E1) to lower mounting arm. (See Figure 18)

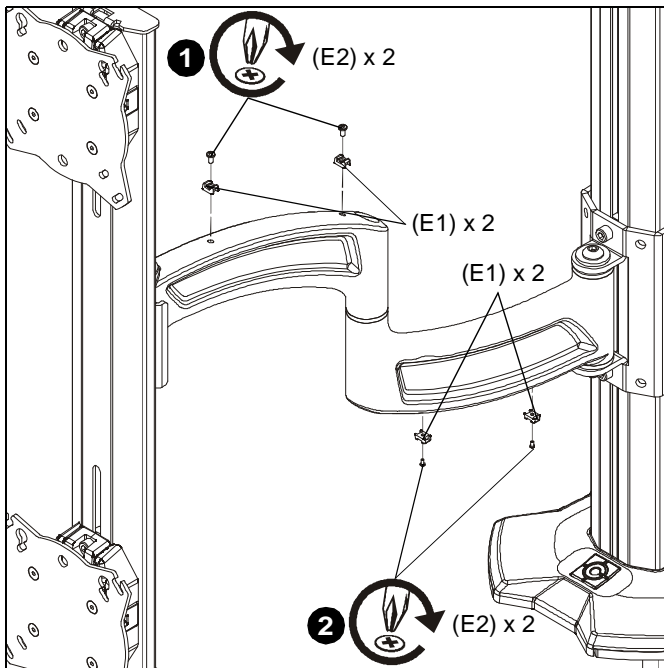

Figure 18

3. Route cables along mounting arms. (See Figure 19)
4. Use cable ties (not included) to secure cables to tie clips (E1). (See Figure 19)

NOTE: Leave enough slack in the cables so that arm may still swing without resistance from the cables.

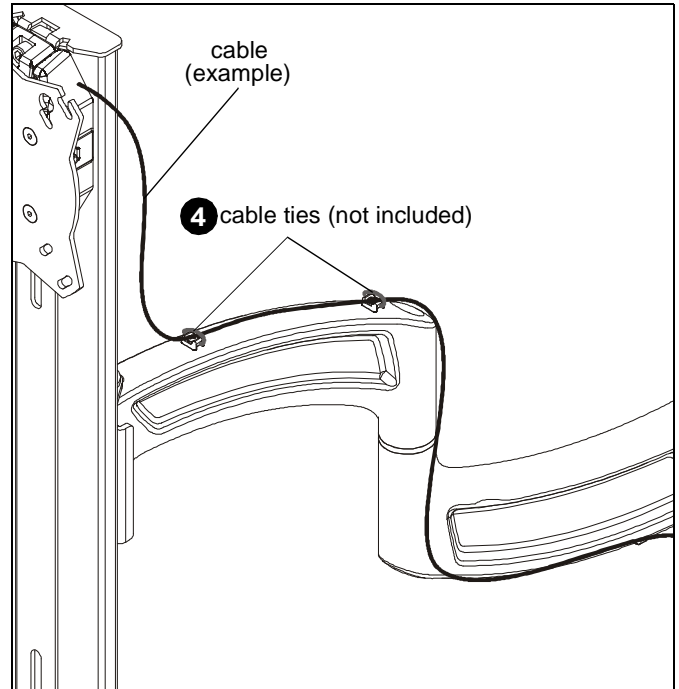

Figure 19

5. Route cables through cable management cover (Y). (See Figure 20)
6. Attach cable management cover (Y) to back of column. (See Figure 20)

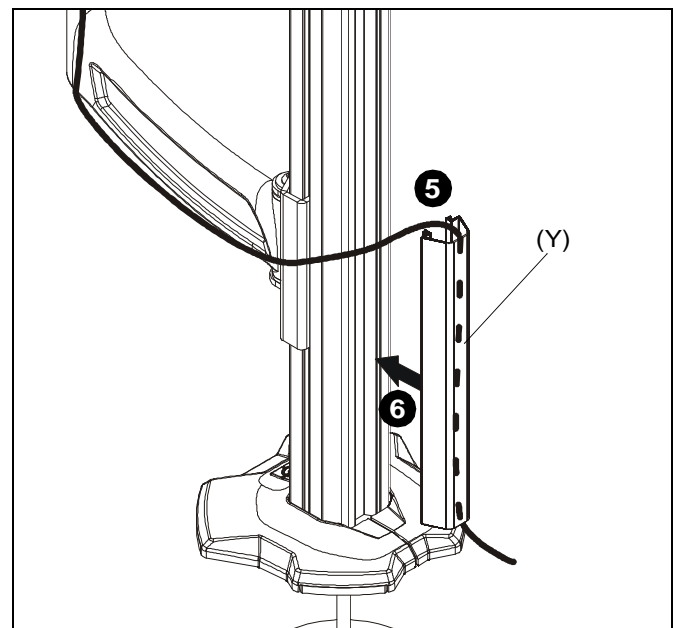

Figure 20



Our Mounts. **Your Vision.**

Chief Manufacturing, a products division
of Milestone AV Technologies

8800-002345 Rev03
©2013 Milestone AV Technologies, a
Duchossois Group Company
www.chiefmfg.com
06/13

USA/International	A 6436 City West Parkway, Eden Prairie, MN 55344 P 800.582.6480 / 952.225.6000 F 877.894.6918 / 952.894.6918
Europe	A Franklinstraat 14, 6003 DK Weert, Netherlands P +31 (0) 495 580 852 F +31 (0) 495 580 845
Asia Pacific	A Office No. 1 on 12/F, Shatin Galleria 18-24 Shan Mei Street Fotan, Shatin, Hong Kong P 852 2145 4099 F 852 2145 4477

