

Adjustments

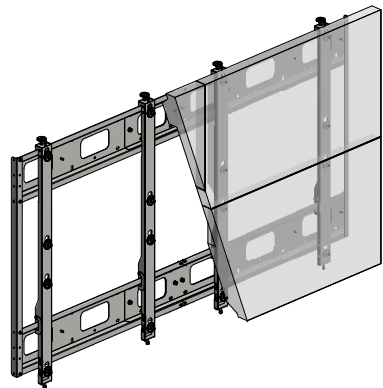
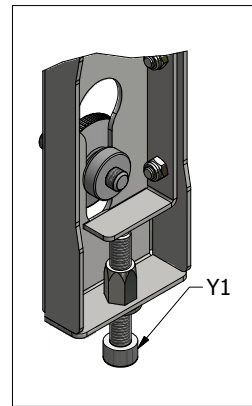
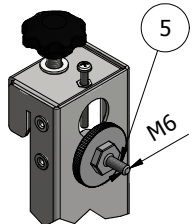
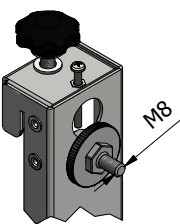

Quick mounting

<p><b>Kit Code 5502</b> <b>Optional</b> <b>for screen Vesa M6</b></p> 	<p>Equipped for screen Vesa M8</p> 
---	--

- Screen Array Configuration : 2x2
- Orientation : Landscape
- Adjustments (Y) : Micro-Adjustments 10mm.
- Adjustments (Y1) : Micro-Adjustments 15mm.
- Adjustments (X) : Adjustments +/- 95mm.
- Adjustments (Z) : Adjustments +/- 7mm.
- Mounting Pattern : Vesa 400x400mm./600x400mm.
- Typical Screen Sizes : 46" / 47"
- Weight Capacity : 30 Kg to Screen
- Galvanized steel shets

POS.	QTY	DESCRIPTION
1	4	OMEGA L=965
2	2	OMEGA JUNCTION
3	2	VERTICAL ANGULAR
4	4	SCREEN BRACKET
5	1	VESA KIT M6 PINS (OPTIONAL)
6	4	SCREEN 46" / 47" VESA 400x400 / 600x400
7		
8		