

Will

And your screen goes mobile !



ORIGINE
FRANCE[®]
GARANTIE

BVCert. 6164725

ERARD[®]



Will 1050 **L**, 1400 **XL** and 1600 **XL**

Discover the Will video
www.erard.com/will

TECHNICAL CHARACTERISTICS

- Screen height adjustment
- Tempered glass shelf
- Epoxy painting
- Width of the column 150 mm



Cable management
in the column



2 colors available:
White and black

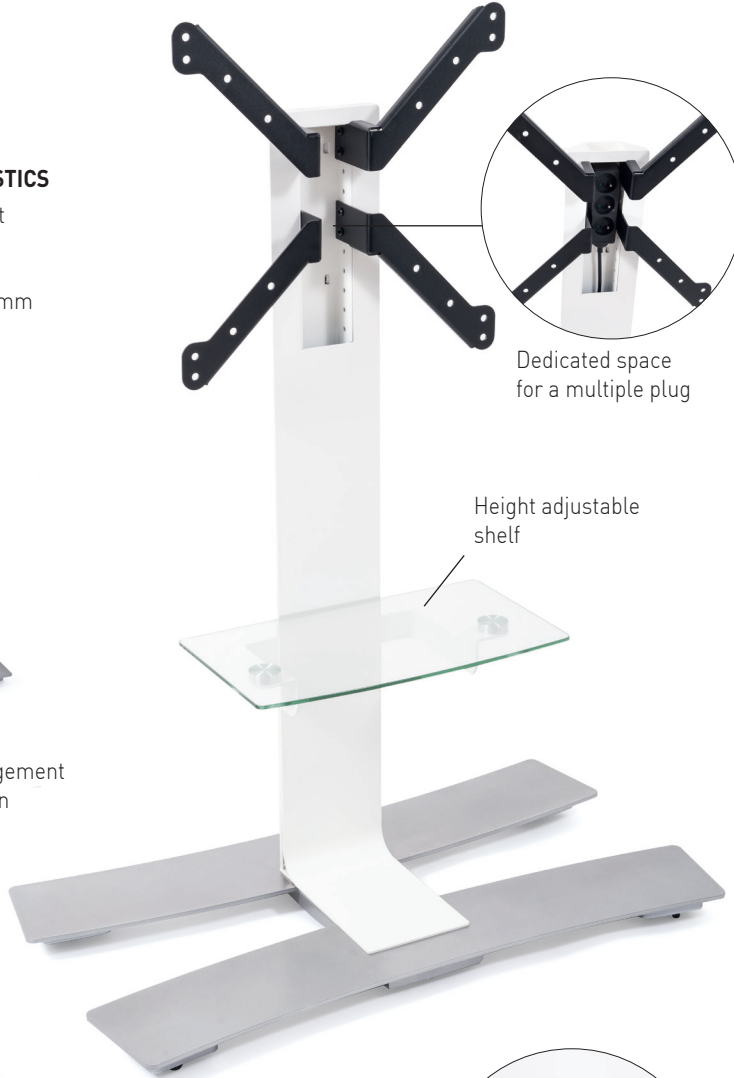

Dedicated space
for a multiple plug

Height adjustable
shelf

Multidirectional
wheels

Will 1050 L

Ref.	039020 - White	EAN	318528 039020 5
Ref.	039021 - White + shelf	EAN	318528 039021 2
Ref.	039030 - Black	EAN	318528 039030 4
Ref.	039031 - Black + shelf	EAN	318528 039031 1

- Screen height adjustment on 125 mm
- Height adjustment of the shelf +/- 75 mm
- Steel base of 6 mm
- 6 multidirectional wheels Ø 35 mm

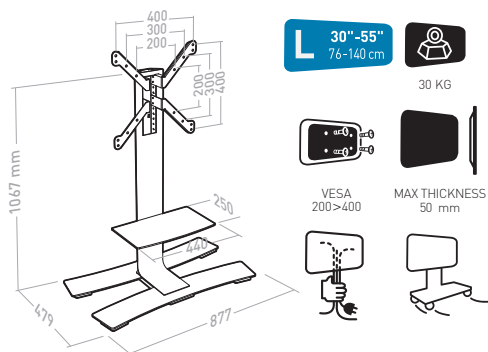

Will 1400 XL

Ref.	039040 - White	EAN	318528 039040 3
Ref.	039041 - White + shelf	EAN	318528 039041 0
Ref.	039050 - Black	EAN	318528 039050 2
Ref.	039051 - Black + shelf	EAN	318528 039051 9

- Screen height adjustment on 125 mm
- Height adjustment of the shelf +/- 100 mm
- Steel base of 8 mm
- 6 multidirectional wheels Ø 35 mm
- Possibility to mount the screen in portrait or landscape (except Vesa 600x400)

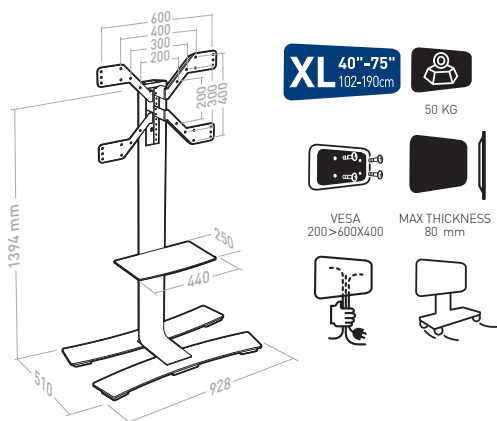

Will 1600 XL

Ref.	039060 - White	EAN	318528 039060 1
Ref.	039070 - Black	EAN	318528 039070 0

- Screen height adjustment on 200 mm
- Steel base of 8 mm
- 10 multidirectional wheels Ø 35 mm
- Possibility to mount the screen in portrait or landscape

- Shelf as an option

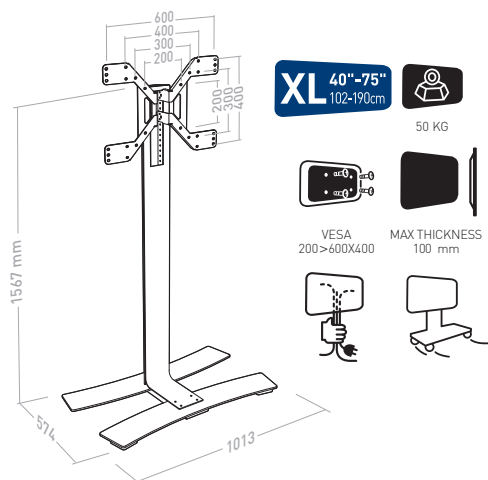

Options

Shelf

Ref.	039080 - White	EAN	318528 039080 9
Ref.	039090 - Black	EAN	318528 039090 8

- Additional shelf for a peripheral
- Height adjustment
- Tempered 6 mm glass shelf, max weight 5 kg
- Dimensions: 440 X 250 mm
- Total thickness: 72 mm

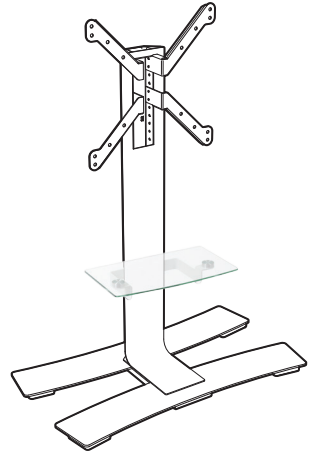

Box-Up

Ref.	038401	EAN	318528 038401 3
------	---------------	-----	-----------------

- Peripheral holder positioned on the rear side of the column
- Steel structure, black epoxy painting
- Peripheral is hold in place thanks to 3 elastic cords
- Reversible right / left

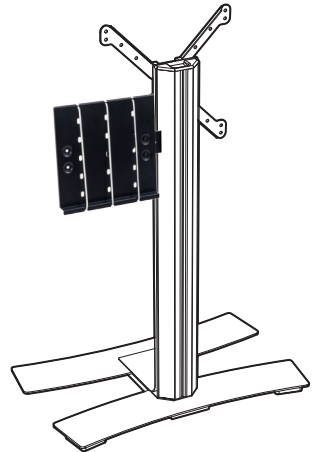

ERARD®

ESSENTIAL ACCESSORIES
FOR AUDIO VIDEO COMPONENTS

Mail: export@erard.fr / www.erard.com / Tel: +33 (0)4 72 46 16 26 / Fax: +33 (0)4 72 46 16 22

VAT number : FR 81 403 591 415

Z.I. de Chavanoz / 4 route de la Plaine / 38236 CHAVANOZ / FRANCE

