

KROSS FLIP 2

Ref. 180024

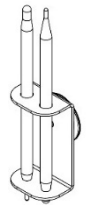

Tablette en verre / Glass shelf
Ref. 180005 (option)

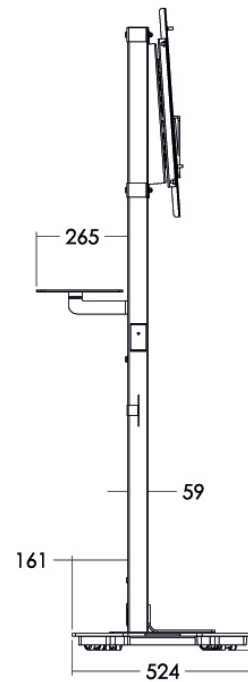
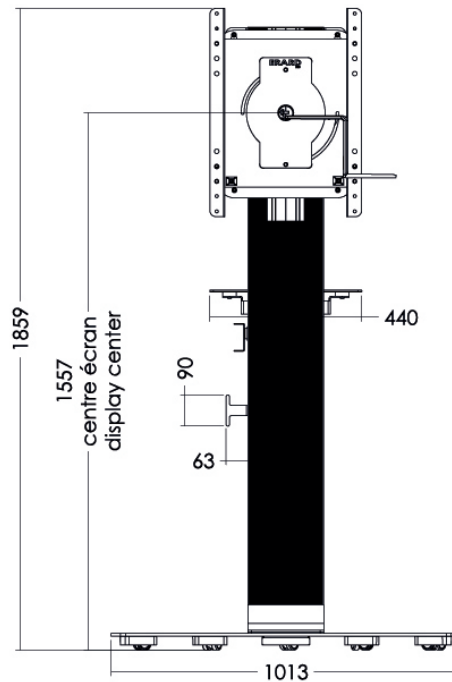

CARACTERISTIQUES TECHNIQUES	TECHNICAL CHARACTERISTICS
<ul style="list-style-type: none"> • Colonne agile : passe dans les espaces étroits grâce à son profil fin 	<ul style="list-style-type: none"> • Easy-to-handle stand even in the narrow spaces thanks to its thin profile
<ul style="list-style-type: none"> • Encombrement au sol limité : socle peu profond (52cm seulement) 	<ul style="list-style-type: none"> • Limited floor space required : small depth of the base (52 cm only)
<ul style="list-style-type: none"> • Déport connectique intégré à l'arrière avec prises USB-B, USB-A, prise HDMI et RJ45 	<ul style="list-style-type: none"> • Connectivity offset with USB-B jack, USB-A jack, HDMI and RJ45
<ul style="list-style-type: none"> • Accès facile à la connectique 	<ul style="list-style-type: none"> • Easy access to connectivity
<ul style="list-style-type: none"> • Support rotatif réglable en hauteur 	<ul style="list-style-type: none"> • Adjustable height for the rotative screen mount
<ul style="list-style-type: none"> • Ecran en mode portrait ou paysage 	<ul style="list-style-type: none"> • Use FLIP display in portrait or landscape mode
<ul style="list-style-type: none"> • Support écran universel pour tous les écrans FLIP 55" V1 et V2 et 65" 	<ul style="list-style-type: none"> • Universal screen mount for all FLIP screens: 55" V1 and V2 and 65"
<ul style="list-style-type: none"> • Ecran incliné de 5° permettant ainsi une saisie tactile plus ergonomique 	<ul style="list-style-type: none"> • 5° tilted screen makes the tactile input more ergonomic
<ul style="list-style-type: none"> • Passage de câbles dans la colonne 	<ul style="list-style-type: none"> • Cable management in the column
<ul style="list-style-type: none"> • Deux accessoires inclus : <ul style="list-style-type: none"> ○ Porte-stylets aimanté à positionner où bon vous semble grâce à sa pastille magnétique ○ Enrouleur de câbles à installer au dos de la colonne 	<ul style="list-style-type: none"> • 2 accessories included <ul style="list-style-type: none"> ▪ Magnetic pen holder to position it wherever you want ▪ Cable rewriter (can be installed at the back of the stand)
<ul style="list-style-type: none"> • Tablette en verre à l'arrière réglable en hauteur (en option, réf. 180005) 	<ul style="list-style-type: none"> • Adjustable glass shelf to fix in the back of the column (optional, ref. 180005)
<ul style="list-style-type: none"> • Poids net : 39kg 	<ul style="list-style-type: none"> • Net weight : 39kg