

**"LED REACH"**

**Guida di montaggio**  
**Montageanleitung**  
**Guia de montaje**  
**Monteringsvejledning**

**Mounting instructions**  
**Prescriptions de montage**  
**Montagevoorschrift**  
**Prescrições de montagem**

**I****Avvertenza:**

Un montaggio corretto è di fondamentale importanza. Peso massimo del TV al plasma o LCD supportato: Kg. 50 (125 lbs). La parete per l'ancoraggio deve essere di legno massiccio, di mattoni pieni o di cemento. **E' necessario impiegare il materiale di montaggio appropriato. Il produttore non si assume alcuna responsabilità in caso di ancoraggio non corretto. Il fabbricante non si assume alcuna responsabilità in caso di impiego diverso dal sostegno di TV al plasma o LCD.**

**D****Beachten Sie bitte:**

Eine korrekte Montage ist von grundsätzlicher Bedeutung. Das Höchstgewicht des Plasma- und LCD-Fernseher-/Bildschirms muß Kg. 50 (125 lbs) sein. Die Verankerungswand muß aus Massivholz, Vollstein oder Zement sein. **Bitte entsprechend geeignetes Montagematerial benutzen. Der Hersteller haftet weder bei unkorrekter Verankerung. Für eine Benutzung anders als für Plasma- und LCD-Fernseher-/Bildschirme ist der Hersteller nicht verantwortlich.**

**E****Atención**

El montaje correcto es de importancia esencial. Peso máximo del TV plasma y LCD: Kg. 50 (125 lbs). Instalar únicamente en paredes de ladrillos o de cemento o sobre columnas de madera maciza. No fijar a un entablado o machihembrado de madera pues no tendría suficiente solidez. La instalación requerirá la utilización de material de fijación apropiado. **El fabricante sólo se responsabiliza de su uso como soporte de TV plasma y LCD-**

**DK****Bemærk!**

En korrekt montage er yderst vigtig. Max vægt af plasma- og LCDskaerme er Kg. 50 (125 lbs). Montering kun på vægge af sten, beton og på træstetter. **Kræver andre monteringsmidler. Benyttes andet end videoapparater plasma- og LCDskaerme garantien.**

**GB****Warning:**

Correct assembly is essential. The maximum weight of supported TV plasma and LCD must not exceed Kg. 50 (125 lbs). The wall to which it is to be attached must be of solid wood, brickwork or concrete. **Require appropriate assembly materials. The manufacturer is not responsible for any consequences deriving from incorrect assembly or for use other than for TV plasma and LCD sets.**

**F****Attention:**

Un montage correct revêt une importance fondamentale. Poids maximum de écran plat: Kg. 50 (125 lbs). La paroi de fixation doit être en bois massif, en briques pleins ou en ciment. **Est nécessaire d'utiliser le matériel de montage approprié. Le fabricant n'assume aucune responsabilité aussi bien en cas de fixation incorrecte qu'en cas d'application différente de celle de support de postes de écran plat.**

**NL****Waarschuwing**

Correcte montage is van essentieel belang. Maximaal gewicht plasma Televisie's en LCD schermen: Kg. 50 (125 lbs). Montage alleen aan wanden van baksteen of beton of aan houten pilaren. **Gebruikt anders dan voor plasma Televisie's en LCD schermen valt buiten de verantwoordelijkheid van de fabrikant.**

**P****Atenção**

Uma montagem correcta é importância essencial. Peso máximo do TV plasma ou LCD: Kg. 50 (125 lbs). Aplique só em paredes de alvenaria ou de betão ou em vigas de madeira. Será necessário material adequado. **A montagem de TV plasma ou LCD num outro tipo de parede, não é da responsabilidade do fabricante.**

<b>A</b>		1
<b>B</b>	Ø 10x50	6
<b>C</b>	Ø 7x60	6
<b>D</b>	40*25	8
<b>E</b>		1
<b>F</b>		1

<b>G</b>	M6x80	2
<b>H</b>	M6	2
<b>I</b>	M8x55	2
<b>L</b>	M8	2
<b>M</b>		4
<b>N</b>		2

<b>O</b>	70*30	2
<b>P</b>	M6x35	2
<b>Q</b>	Ø 6	1
<b>R</b>	M8x20	4
<b>S</b>	M6x12	4

Subject to technical modifications/ Technische wijzigingen voorbehouden/ Technische Änderungen sind vorbehalten/ Sous réserve de modifications techniques/ Sujeto a modificaciones técnicas/ Con riserva di modifiche tecniche/ Reservado o direito de modificacoes técnicas/ Tekniska ändring ar förbehålles.

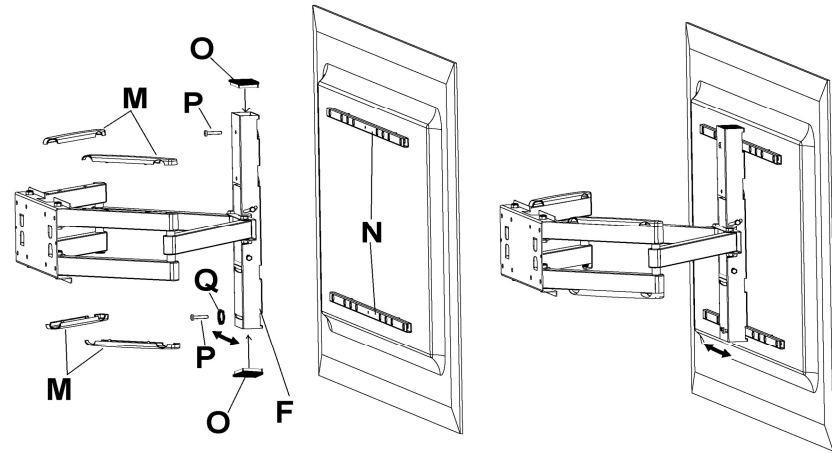
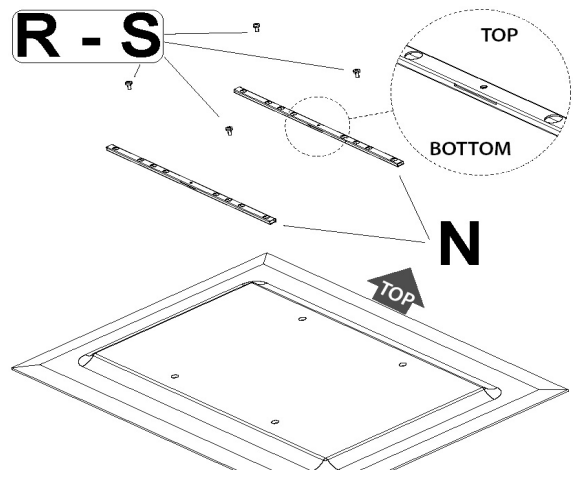
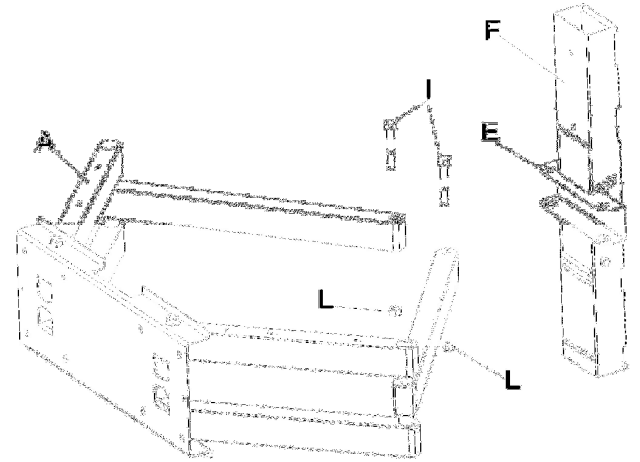
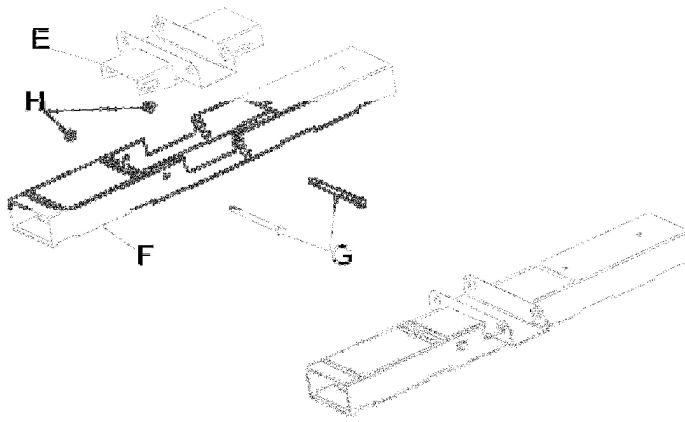
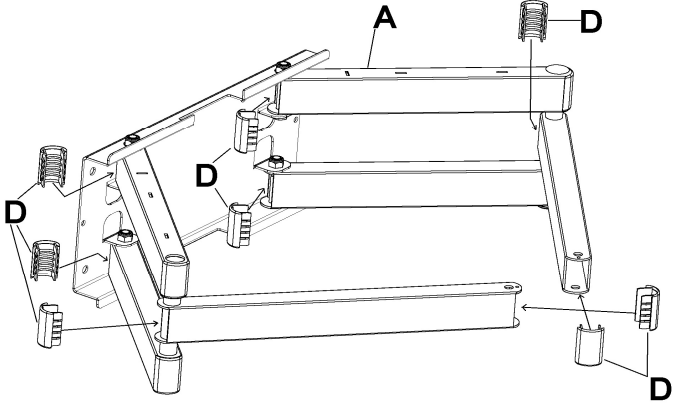
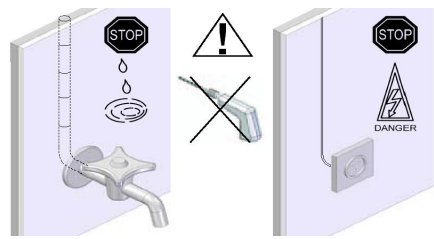
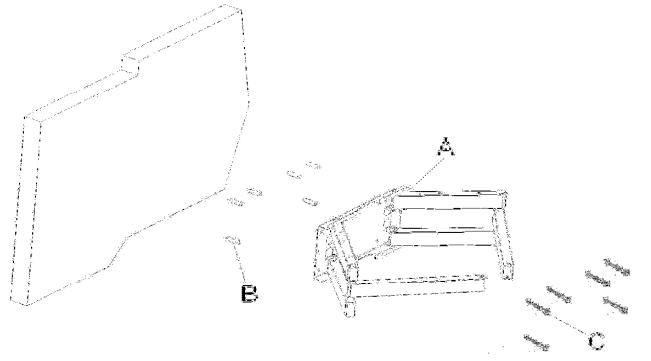
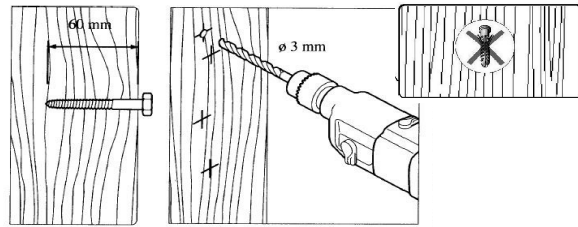
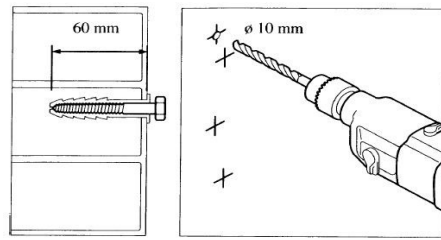
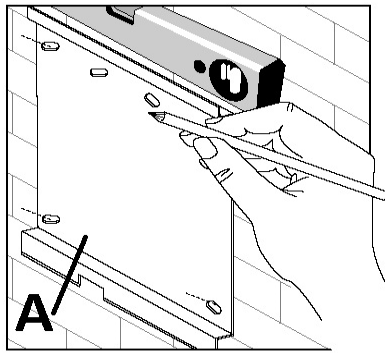
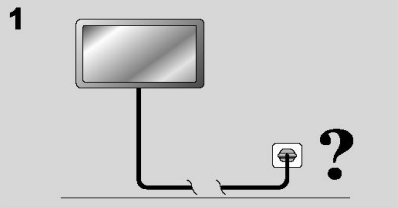

**kg** MAX  
50 Kg

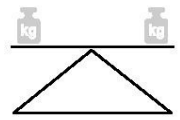

**Cod 02991**